

**英飞特电子（杭州）股份有限公司
客户承认书****SPECIFICATION FOR APPROVAL****CUSTOMER/客户:** _____ **UNICOBA ENERGIA S.A.****CUSTOMER P.N./客户物料号:** _____**MODEL NO./产品型号:** _____ **EUG-096S105DT-UC01****CUSTOMER MODEL NO./客户产品型号:** _____**SAMPLE DATE/送样日期:** _____

CUSTOMER AUTHORIZED SIGNATURE/客户承认签核		

Please return to us one copy of "SPECIFICATION FOR APPROVAL" with your approved signature.
客户确认签字，盖章后请回传一份承认书给我司。

Inventronics (Hangzhou), Inc.

研发基地：浙江省杭州市滨江区江虹路459号英飞特科技园A座（310052）

制造基地：浙江省桐庐县桐庐经济开发区环城南路88号

R&D Add: Building A ,Inventronics Science and Technology Park,#459 Jianghong Road, Binjiang District, Hangzhou, Zhejiang 310052, P. R. China.**MFG Add:** NO.88 South Huancheng Road.,Economic Development Zone of TongLu,TongLu County,Zhejiang 310052,P. R. China.**Tel:** 86-571-56565800**Fax:** 86-571-86601139**Email:** sales@inventronics-co.com

Prepared By : 拟制:		Checked By : 审核:		Approved By : 批准:	
-----------------------------	--	----------------------------	--	-----------------------------	--

Revision History/变更履历表

Rev.	Date	Revision Description	Reviser	Customer Approval	Approval Date
V1.0	2018.03.14	First Release./第一次发行	Anna Xiao		
V2.0	2019.01.16	Update Label Drawing/标签图纸更新 Update Environmental /环境要求更新	Shelly Kuang		
V3.0	2019.01.26	Update Label Drawing/标签图纸更新 Update Environmental /环境要求更新	Shelly Kuang		

Table Of Content/目录

1. Scope /简述	4
2. Input Characteristics /输入特性	4
2.1. Input Conditions/输入条件	4
2.2. Line Voltage Surge and Brownout/输入电压浪涌和掉电	4
2.3. Inrush Current(Cold Start) /浪涌电流（冷启动）	4
2.4. Power Efficiency(Normal) /效率（额定输入）	5
3. Output Characteristics /输出特性	5
3.1. Output Conditions/输出条件	5
3.2. I-V Operation Area/ I-V 工作区域	6
3.3. Ripple & Noise (pk-pk) /纹波&噪声(pk-pk)	6
3.4. Line regulation/线性调整率	6
3.5. Load regulation/负载调整率	6
3.6. Turn on delay time/开机延迟时间	6
4. Dimming Control(On secondary side) /调光控制	7
4.1. 0-5V dimming/0-5V 调光	8
4.2. 0-10V dimming/0-10V 调光	9
4.3. PWM dimming/PWM 调光	10
4.4. Timer/定时调光	11
5. Protection /电源保护功能	11
5.1. Over Voltage Protection /过压保护	11
5.2. Short Circuit Protection /短路保护	11
5.3. Over Temperature Protection /过温保护	12
6. Safety and EMC Compliance/安规及 EMC 标准	12
6.1. Safety Standards/安规标准	12
6.2. EMI Standards/ EMI 标准	12
6.3. EMS Standards/ EMS 标准	12
6.4. Dielectric Strength (Hi-pot)/介电耐压强度（高压）	13
6.5. Leakage Current/漏电流	13
6.6. Ground Resistance/接地阻抗	13
7. Environmental /环境要求	13
7.1. Temperature/温度	13
7.2. Humidity/湿度	13
8. Reliability /可靠性	14
8.1. Burn-in/老化	14
8.2. MTBF Qualification/平均间隔故障时间估算	14
8.3. Life/寿命	14
9. Waterproof /防水等级	14
10. Label Drawing/标签图纸	15
11. Mechanical 2D Drawing /2D 机构图	16
12. Package Drawing/包装外观图	17

1. Scope / 简述

The power supply described here is a 96W Dimming Control programmable AC/DC CC LED driver with (700-1050mA) single output. This unit is designed to meet the relevant safety and EMC regulations. The power supply shall meet the RoHS requirement.

此款为96W单路输出(700-1050mA)带调光控制可编程恒功率电源。设计符合安规和EMC标准。此款电源符合RoHS要求。

2. Input Characteristics / 输入特性

2.1. Input Conditions / 输入条件

Rated input voltage / 额定输入电压	100-240/277Vac
Operating range / 输入电压范围	90-305Vac
Rated input frequency / 额定输入频率	50/60Hz (+/-3Hz)
Input power / 输入功率	103W _{Typ.} @220Vac
Input current / 输入电流	0.47A _{Typ.} @220Vac
Power Factor / 功率因数	0.96 _{Typ.} @220Vac, 100%load
THD / 总谐波失真	≤10% @220-240Vac, 50-60Hz, 75% -100%load (72-96W)

2.2. Line Voltage Surge and Brownout / 输入电压浪涌和掉电

Surge / 浪涌

With the PSU operating at minimum and maximum load, the power supply shall survive at the input surge voltage of 330Vac for 60 seconds.

电源可承受最大输入电压330Vac，60秒不损坏。

AC Line Brownout / AC 输入电压掉电

The PSU shall not be damaged under 90Vac input voltage in short using time.

输入电压短时低于90Vac时，电源不损坏。

2.3. Inrush Current (Cold Start) / 浪涌电流（冷启动）

1.65 A²s max. @ 220Vac input, 25°C cold start, duration=760us, 10%Ipk-10%Ipk.

1.65 A²s max. @ 220Vac, 25°C（冷机启动），10%Ipk -10%Ipk，持续时间=760us。

2.4. Power Efficiency(Normal) /效率（额定输入）

88.5% min. (91.5% typ.) Measured at full load, 120Vac input, 25°C ambient temperature, after the unit is thermally stabilized. It will be about 2% lower, if measured immediately after startup.

88.5% min.（典型值91.5%）@ 120Vac, 满载，25°C环温，电源热机后。冷机启动时效率降低约2%。

91.0% min. (93.0% typ.) Measured at full load, 220Vac input, 25°C ambient temperature, after the unit is thermally stabilized. It will be about 2% lower, if measured immediately after startup.

91.0% min.（典型值93.0%）@ 220Vac, 满载，25°C环温，电源热机后。冷机启动时效率降低约2%。

91.5% min. (93.5% typ.) Measured at full load, 277Vac input, 25°C ambient temperature, after the unit is thermally stabilized. It will be about 2% lower, if measured immediately after startup.

91.5% min.（典型值93.5%）@ 277Vac, 满载，25°C环温，电源热机后。冷机启动时效率降低约2%。

Note: All the above specifications are tested at 25°C ambient temperature unless otherwise stated.
注：以上所有规格都是25°C环温测试，除非另有说明。

3. Output Characteristics /输出特性

3.1. Output Conditions/输出条件

Number of output channel/输出路数	1
Default Output Current /出厂默认电流	700mA±5%
Default Output voltage range /出厂默认电压范围	48-137V
Full power adjustable output current /满功率可调整输出电流范围	700-1050mA
Output voltage at no load/空载电压	180V max.
Rated output power/额定功率	96W max.

3.2. I-V Operation Area/ I-V 工作区域

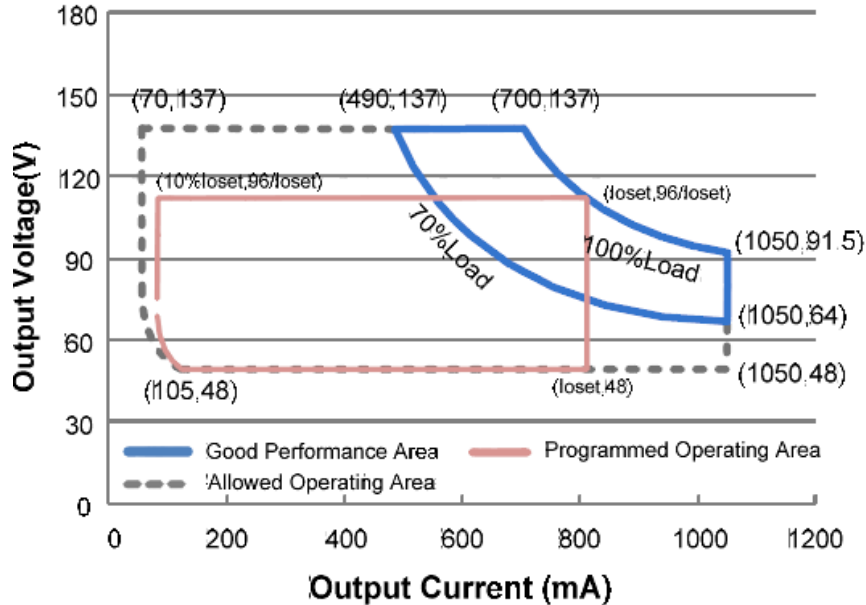

Note: $700\text{mA} \leq \text{I}_{\text{Oset}} \leq 1050\text{mA}$

3.3. Ripple & Noise (pk-pk) /纹波&噪声(pk-pk)

Total Output Current Ripple is less than 10%I_{max}. @ 100%load (measured at 20MHz bandwidth and the output is paralleled with a 0.1uF ceramic capacitor and a 10uF electrolysis capacitor).
总输出电流纹波 $\leq 10\%I_{\text{max}}$. @满载测试(测试时示波器设置为 20M 带宽, 输出端并联一个 0.1uF 的陶瓷电容和一个 10uF 的电解电容)。

3.4. Line regulation/线性调整率

The line regulation is less than 0.5% when the line voltage changing from minimum input voltage to maximum input voltage @ 100%load.
 $\leq 0.5\%$ @从最小输入电压变化为最大输入电压满载测试。

3.5. Load regulation/负载调整率

The load regulation is less than 1.5% when output load changing from minimum output load to maximum output load.
 $\leq 1.5\%$ @从最小输出负载变化为最大输出负载。

3.6. Turn on delay time/开机延迟时间

Less than 1000mS at rated input voltage 120-277Vac and 70%-100% load.
 $\leq 1000\text{mS}$ @额定输入电压 120-277Vac &70%-100%负载。

Note: All the above specifications are tested at 25°C ambient temperature unless otherwise stated.
注: 以上所有规格都是 25°C 环温测试, 除非另有说明。

4. Dimming Control(On secondary side) /调光控制

Parameter/参数	Min./最小	Typ./典型	Max./最大	Notes/备注
Vaux output voltage /Vaux 输出线电压	10.8V	12V	13.2V	
Vaux output source current /Vaux 输出线电流	0mA		20mA	Return terminal is "Dim-" /参考地为 "Dim-"
Absolute maximum voltage Range on the 0-5V/0~10V input pin /0-5V/0~10V 线上最大电压	-20 V	-	20 V	
Source current on 0-5V/0~10V input pin /0-5V/0~10V线上电流	200 uA	300 uA	450 uA	Vdim(+) = 0V
Dimming output range /调光输出范围	10%loset	-	100%loset	700mA ≤ loset ≤ 1050mA
	70mA	-	loset	70mA ≤ loset < 700mA
Recommended dimming input range0-10V /0-10V推荐调光输入	0 V	-	10 V	Default 0-10V dimming mode with Positive logic. /调光缺省设置是正逻辑 0-10V调光模式。
Recommended dimming input range0-5V /0-5V推荐调光输入	0 V	-	5 V	Dimming mode set to 0-5V in PC interface. /调光模式在PC界面设置 是0-5V调光。
PWM HL/PWM高电平	3V	-	10V	Dimming mode set to PWM in PC interface. /调光需通过PC界面设置。
PWM LL/PWM低电平	-0.3V	-	0.6V	
PWM frequency range /PWM频率范围	200Hz	-	2KHz	
PWM duty cycle/PWM 占空比	1%	-	99%	

Note: All the above specifications are tested at 25°C ambient temperature unless otherwise stated.

注：以上所有规格都是25°C环温测试，除非另有说明。

4.1. 0-5V dimming/0-5V 调光

Positive logic/正逻辑：

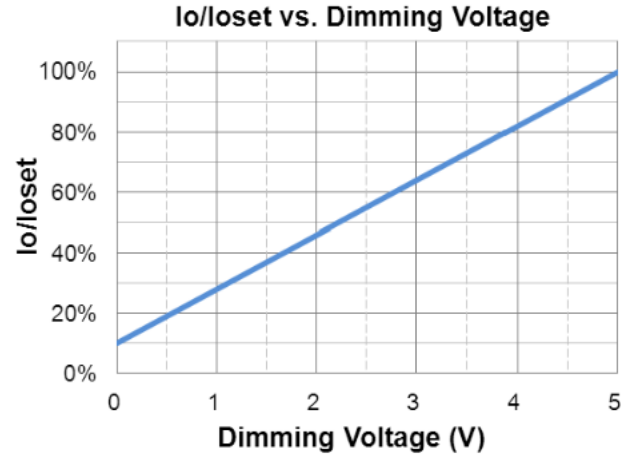
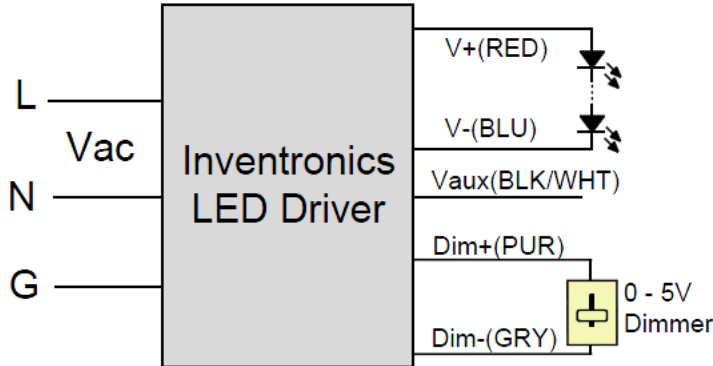

Implementation 1: Positive logic

Negative logic/负逻辑：

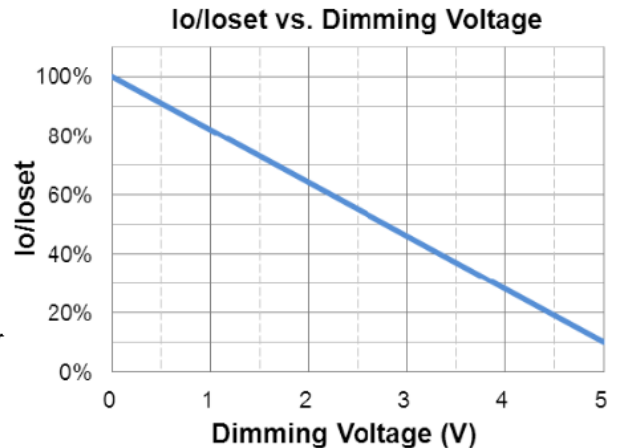
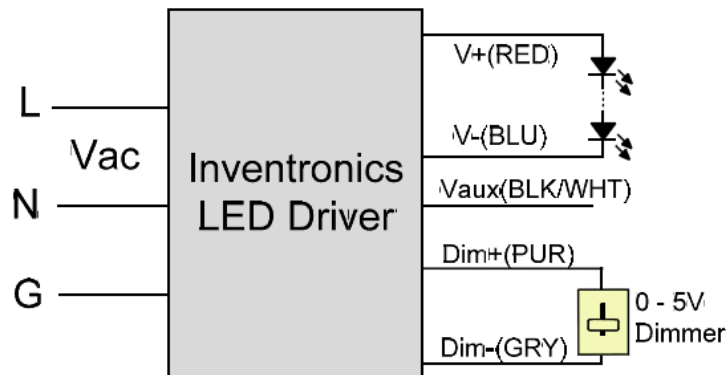

Implementation 2: Negative logic

Notes:

1. The dimmer can also be replaced by an active 0-5V voltage source signal or passive components like resistors and zener.
2. Do not connect the dimming wire to the output wire; otherwise, the LED driver cannot work normally.
3. If 0-5V dimming is not used, dimming wire should be open.
4. When 0-5V negative logic dimming mode and Dim+ is open, the driver will output maximum current.

注：

1. 可用有源0-5V电压源信号或者无源元件，比如电阻或者稳压管，来替代调光器。
2. 不能将调光线连接到输出线上，否则驱动器无法正常工作。
3. 调光功能不使用时，调光线可悬空。
4. 当0-5V负逻辑调光模式的调光线Dim+是悬空的，则驱动器输出最大电流。

4.2. 0-10V dimming/0-10V 调光

Positive logic/正逻辑：

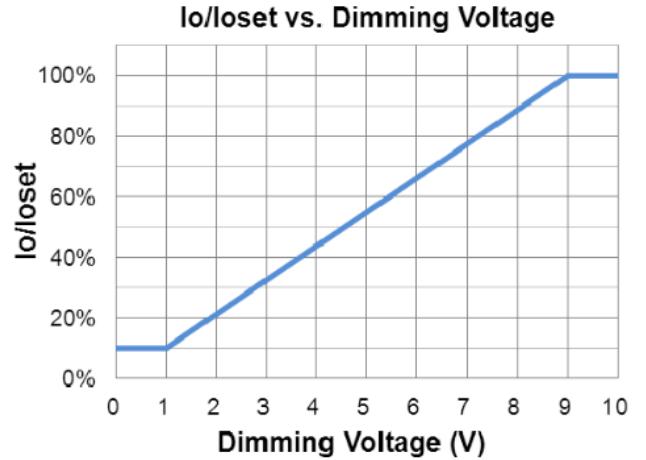
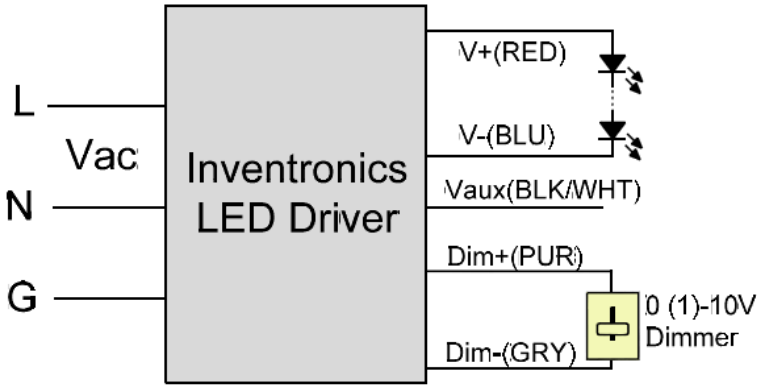

Implementation 3: Positive logic

Negative logic/负逻辑：

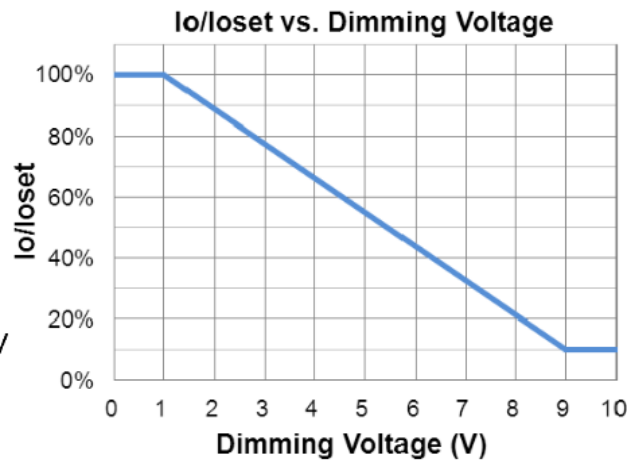
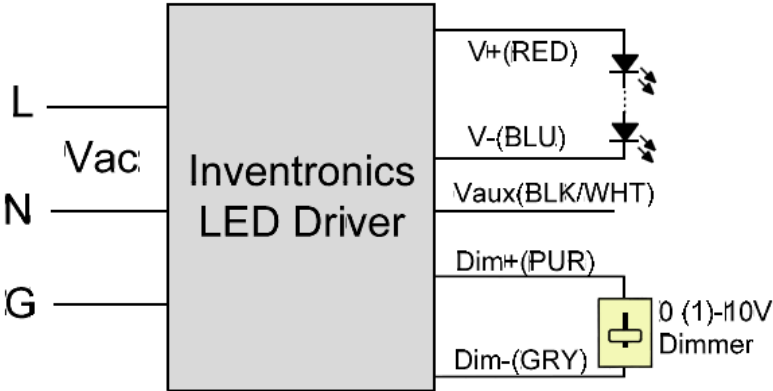

Implementation 4: Negative logic

Notes:

1. The dimmer can also be replaced by an active 0-10V voltage source signal or passive components like resistors and zener.
2. Do not connect the dimming wire to the output wire; otherwise, the LED driver cannot work normally.
3. If 0-10V dimming is not used, dimming wire should be open.
4. When 0-10V negative logic dimming mode and Dim+ is open, the driver will output minimum current.

注：

1. 可用有源0-10V电压源信号或者无源元件，比如电阻或者稳压管，来替代调光器。
2. 不能将调光线连接到输出线上，否则驱动器无法正常工作。
3. 调光功能不使用时，调光线可悬空。
4. 当0-10V负逻辑调光模式的调光线Dim+是悬空的，则驱动器输出最小电流。

4.3. PWM dimming/PWM 调光

Positive logic/正逻辑：

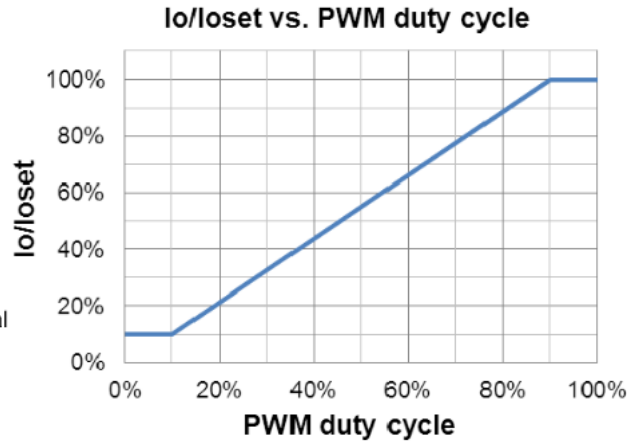
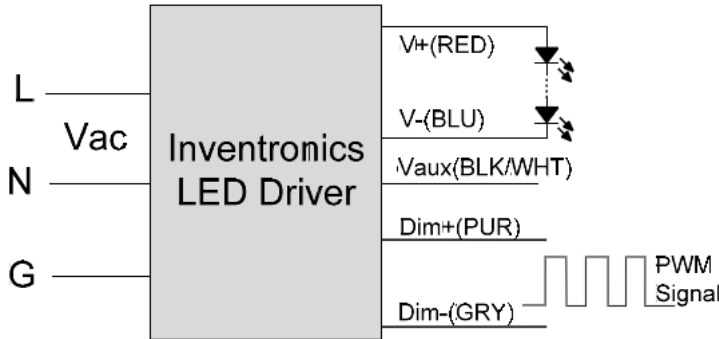

Implementation 5: Positive logic

Negative logic/负逻辑：

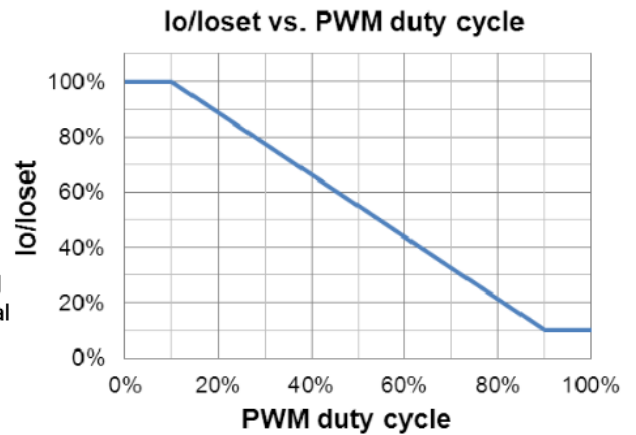
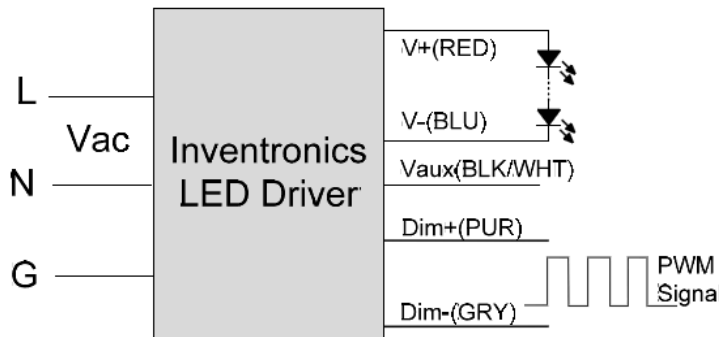

Implementation 6: Negative logic

Notes:

1. Do not connect the dimming wire to the output wire; otherwise, the LED driver cannot work normally.
2. If PWM dimming is not used, dimming wire should be open.
3. When PWM negative logic dimming mode and Dim+ is open, the driver will output minimum current.

注：

1. 不能将调光线连接到输出线上，否则驱动器无法正常工作。
2. 调光功能不使用时，调光线可悬空。
3. 当PWM负逻辑调光模式的调光线Dim+是悬空的，则驱动器输出最小电流。

4.4. Timer/定时调光

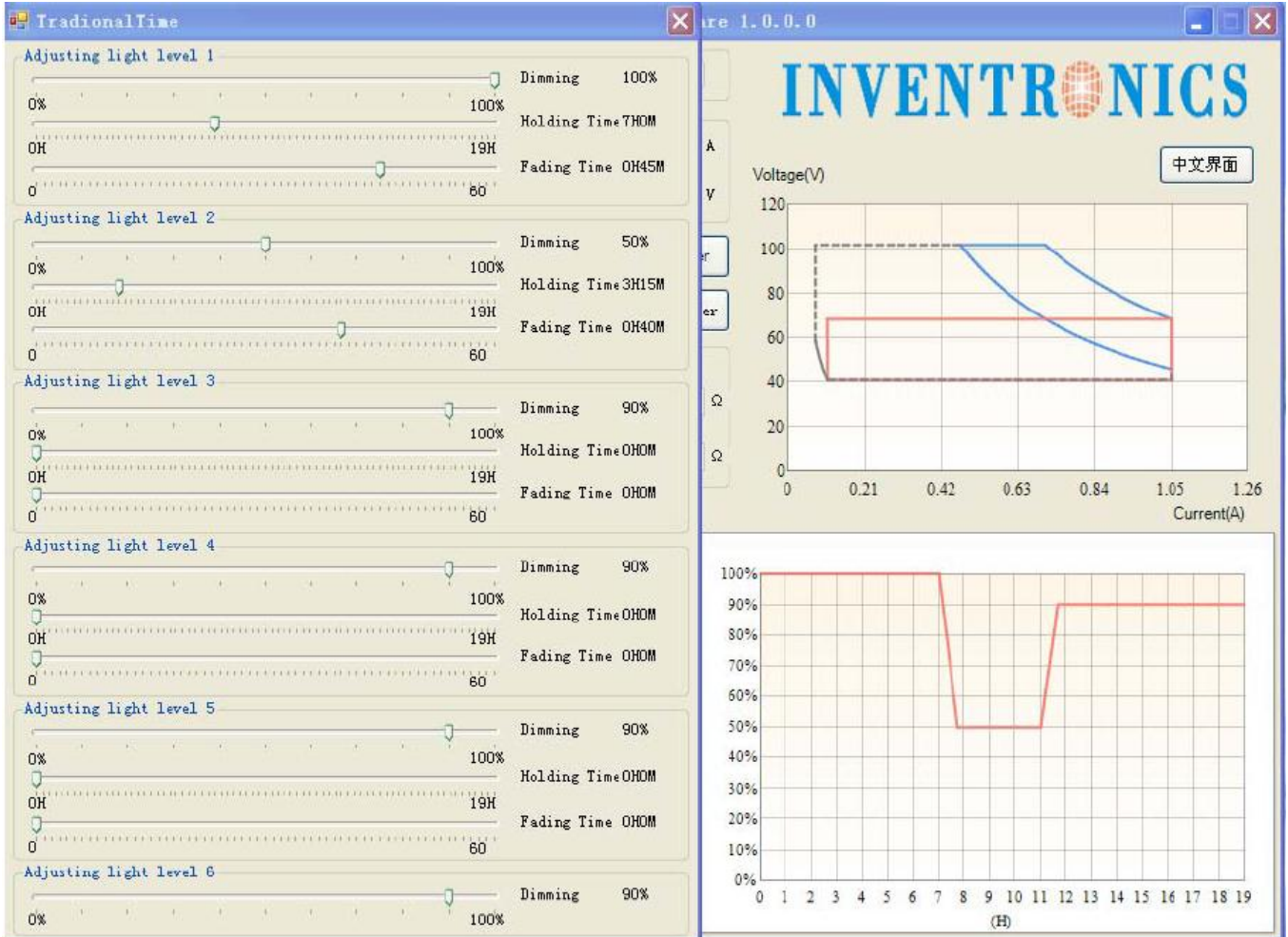

Set the output current dimming curve by moving the sliding block/移动滑块可进行调光曲线设置。

5. Protection /电源保护功能

5.1. Over Voltage Protection /过压保护

The unit will go into OVP protection when the OVP trigger voltage exceeds OVP point. Limits output voltage at no load and in case the normal voltage limit fails.

产品过压时，电源会启动 OVP 保护功能。输出电压会限制在规定范围内。

5.2. Short Circuit Protection /短路保护

When the output is shorted, and the power supply shall not be damaged, and shall be recovered after the fault condition is removed.

短路时，产品无损伤。短路解除后，可自动恢复。

5.3. Over Temperature Protection /过温保护

The power supply shall go into thermal protection as the internal temperature of the unit exceeds internal limitation. The output shall be auto recovery when the temperature becomes normal.

电源内部实际温度超过内部限定温度时会启动过温保护。温度正常时，输出自动恢复。

6. Safety and EMC Compliance/安规及 EMC 标准

6.1. Safety Standards/安规标准

Safety category /安规	Country /国家	Standard/标准
CE	Europe	EN61347-1, EN61347-2-13
UL /CUL	USA & Canada	UL 8750, UL 1310, CAN/CSA-C22.2 No. 250.13-12, CAN/CSA-C22.2 No. 223-M91

6.2. EMI Standards/ EMI 标准

EMI Standards	Notes
EN 55015	Conducted emission Test & Radiated emission Test
EN 61000-3-2	Harmonic current emissions
EN 61000-3-3	Voltage fluctuations & flicker
FCC Part 15	ANSI C63.4:2009 Class B
	This device complies with Part 15 of the FCC Rules. Operation is subject to the following two conditions:(1)this device may not cause harmful interference, and (2)this device must accept any interference received, including interference that may cause undesired Operation.

6.3. EMS Standards/ EMS 标准

EMS Standards	Notes
EN 61000-4-2	Electrostatic Discharge (ESD): 8 kV air discharge, 4 kV contact discharge
EN 61000-4-3	Radio-Frequency Electromagnetic Field Susceptibility Test-RS
EN 61000-4-4	Electrical Fast Transient / Burst-EFT
EN 61000-4-5	Surge Immunity Test: AC Power Line: line to line 6kV, line to earth 10 kV
EN 61000-4-6	Conducted Radio Frequency Disturbances Test-CS
EN 61000-4-8	Power Frequency Magnetic Field Test.
EN 61000-4-11	Voltage Dips.

EMS Standards	Notes
EN 61547	Electromagnetic Immunity Requirements Applies To Lighting Equipment

6.4. Dielectric Strength (Hi-pot)/介电耐压强度（高压）

- a) Input-Output:3000Vac/10mA/60s is guaranteed(In the process of manufacturing testing time for 1s.), when the nut and gasket is dismantled.
输入-输出:3000Vac/10mA/60s(生产时高压测试时间:1s), 拆除六角螺母和接地垫片。
- b) Input-Earth:2100Vac/5mA/60s is guaranteed(In the process of manufacturing testing time for 1s.) , when the nut and gasket is dismantled.
输入-地:2100Vac/5mA/60s(生产时高压测试时间:1s), 拆除六角螺母和接地垫片。
- c) Output- Earth: 1500Vac/5mA/60s is guaranteed(In the process of manufacturing testing time for 1s.) , when the nut and gasket is dismantled.
输出-地: 1500Vac/5mA/60s(生产时高压测试时间:1s), 拆除六角螺母和接地垫片。

6.5. Leakage Current/漏电流

0.75MIU max. @277Vac/60Hz. (Reliable connection of the earth/产品需可靠接地).

6.6. Ground Resistance/接地阻抗

0.1Ω max. 32A, 3S.

7. Environmental /环境要求

7.1. Temperature/温度

Condition/条件	Minimum/最小	Maximum/最大	Notes/备注
Operating Case Temperature for Safety /安规壳温	-40°C	+90°C	/
Operating Case Temperature for Warranty/质保壳温	-40°C	+75°C	/
Operating Temperature/工作温度	-40°C	+65°C	100-277Vac
Storage Temperature /储藏温度	-40°C	+85°C	/

7.2. Humidity/湿度

Condition/条件	Minimum/最小	Maximum/最大	Unit/单位
Operating Humidity /工作湿度	10%	100%	RH
Storage Humidity /储藏湿度	5%	100%	RH

8. Reliability /可靠性

8.1. Burn-in/老化

The power supply unit shall undergo a minimum of 4 Hours burn-in test at $45^{\circ}\text{C} \pm 5^{\circ}\text{C}$ at full load.

产品至少要在 $45^{\circ}\text{C} \pm 5^{\circ}\text{C}$ 的环境及满载条件下老化 4 小时。

8.2. MTBF Qualification/平均间隔故障时间估算

The typical MTBF shall be 339,000 hours at 220Vac input, 80%Load and 25°C Ambient Temperature (MIL-HDBK-217F).

典型值 339,000 小时 @220Vac ,80%负载, 25°C 环温。

8.3. Life/寿命

The typical Life shall be 98,000 hours at 220Vac input, 80%Load; Case temperature= 70°C @ Tc point. See life time vs. Tc curve for the details.

典型值 98,000 小时 @220Vac ,80%负载, 70°C 壳温。

Life Time vs. Case Temperature Curve/寿命 vs.壳温曲线:

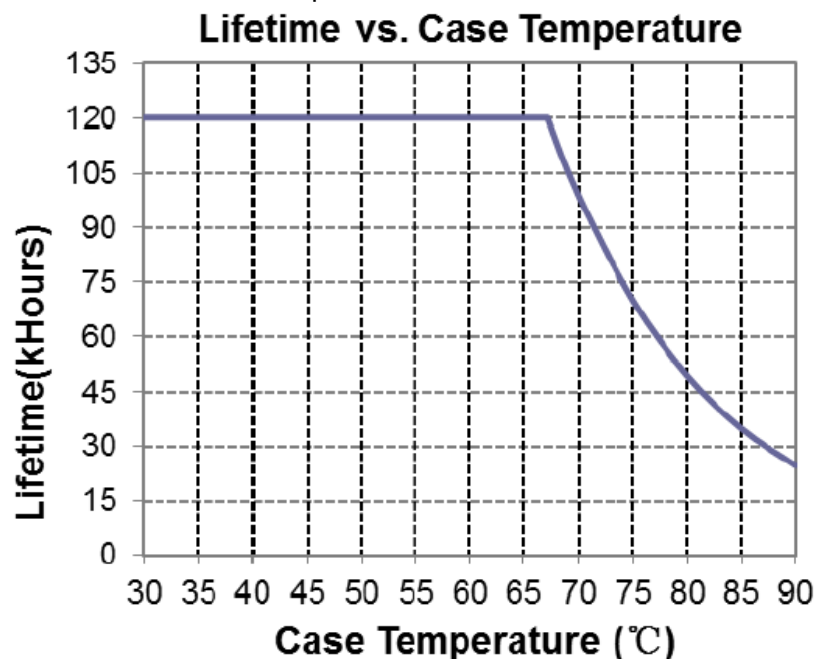

9. Waterproof /防水等级

The PSU come up to IP67 standard.

10. Label Drawing/标签图纸

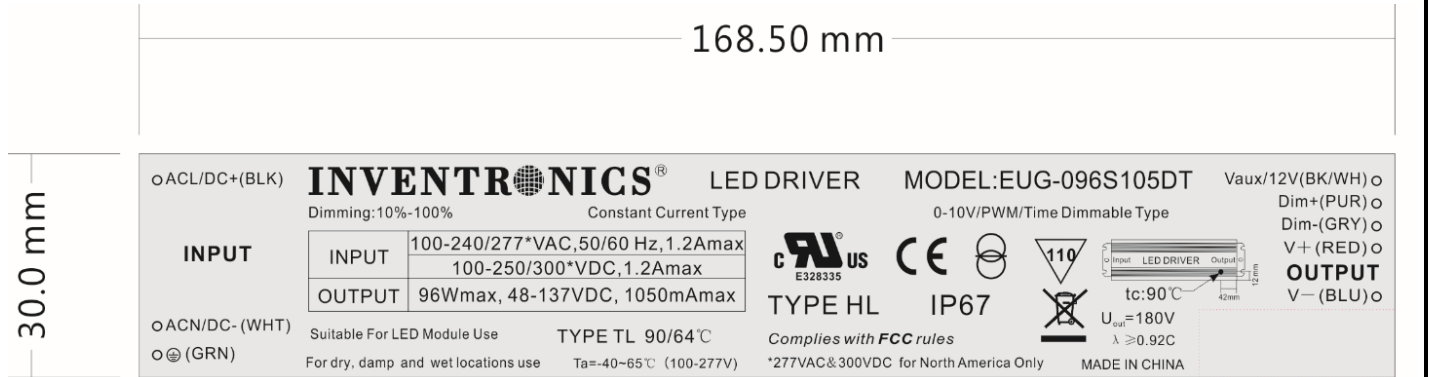

注意：红色虚线框无需印刷，此位置是贴产线内部打印小标签处，小标签尺寸为：26*9

The Small label/小标签:

EUG-096S105DT-UC01
Configuration:N/A
Initial Current: 700mA
Firmware:XXXXXX

Notes:The information of label for constant power product may follow the software upgrading.
注：小标签信息可能随软件版本升级而变更。

11. Mechanical 2D Drawing /2D 机构图

Enclosure material/材质要求	Al 6063
Typical Dimension (L x W x H)/参考尺寸	6.85x 2.66x 1.44 Inch/英寸 174 x67.5 x 36.5 mm/毫米
Typical Net Weight/参考净重	890g
Color/颜色	Silver/银色

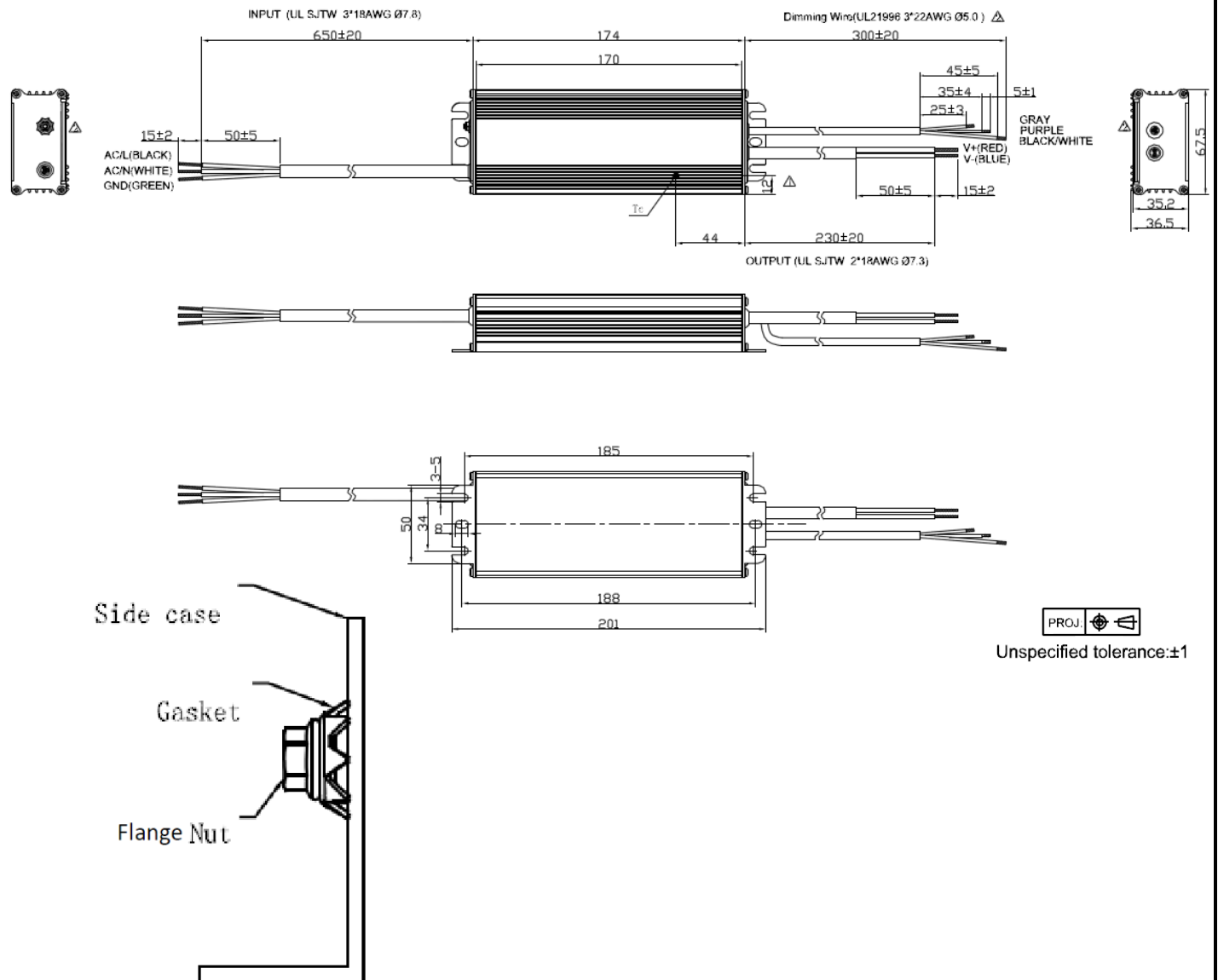

12. Package Drawing/包装外观图

Typical Carton Dimension (L x W x H)/参考包材尺寸	490 x 300 x 305 mm
Pulp Foam Tray/纸箱托盘	4pcs/carton
Shield Board/平卡	4pcs/carton
LED Drivers/LED驱动器	20pcs/carton

